





**BUREAU
VERITAS**

TEST REPORT IEC 61683

Photovoltaic systems – Power conditioners – Procedure for measuring efficiency

Report reference number	PV190308N051-2			
Date of issue	2019-07-05			
Total number of pages	28			
Testing laboratory name	Bureau Veritas Shenzhen Co., Ltd. Dongguan Branch			
Address	No. 34, Chenwulu Section, Guantai Rd., Houjie Town, Dongguan City, Guangdong 523942, China			
				
	Certificate # 2951.01			
Applicant's name	EVOLVE ENERGY GROUP CO., LIMITED			
Address	RM 702, 7/F FU FAI COMM CTR 27 HILLIER ST SHEUNG WAN, HK			
Test specification				
Standard.....	IEC 61683:1999;			
Certificate	Certificate of compliance			
Test report form number	IEC61683			
Master TRF	Bureau Veritas Consumer Products Services Germany GmbH			
Test item description	Solar Grid-tied Inverter			
Trademark.....	EVVO			
Model / Type	EVVO 20000TLG23P, EVVO 25000TLG23P, EVVO 30000TLG23P, EVVO 33000TLG23P			
Ratings	EVVO 20000TLG23P	EVVO 25000TLG23P	EVVO 30000TLG23P	EVVO 33000TLG23P
Input DC voltage range [V].....	230-1100			
Full load MPPT DC voltage range [V]:	480-850	460-850	520-850	580-850
Input DC current [A]	24/24	28/28	30/30	30/30
Output AC voltage [V]	400V, 3/N/PE, 50Hz			
Output AC current [A].....	Max. 32	Max. 40	Max. 48	Max. 53
Output power [VA].....	22000	27500	33000	36300
<small>This report is governed by, and incorporates by reference, CPS Conditions of Service as posted at the date of issuance of this report at http://www.bureauveritas.com/home/about-us/our-business/cps/about-us/terms-conditions and is intended for your exclusive use. Any copying or replication of this report to or for any other person or entity, or use of our name or trademark, is permitted only with our prior written permission. This report sets forth our findings solely with respect to the test samples identified herein. The results set forth in this report are not indicative or representative of the quality or characteristics of the lot from which a test sample was taken or any similar or identical product unless specifically and expressly noted. Our report includes all of the tests requested by you and the results thereof based upon the information that you provided to us. Measurement uncertainty is only provided upon request for accredited tests. You have 60 days from date of issuance of this report to notify us of any material error or omission caused by our negligence or if you require measurement uncertainty; provided, however, that such notice shall be in writing and shall specifically address the issue you wish to raise. A failure to raise such issue within the prescribed time shall constitute your unqualified acceptance of the completeness of this report, the tests conducted and the correctness of the report contents.</small>				

Testing Location	Bureau Veritas Shenzhen Co., Ltd. Dongguan Branch
Address	No. 34, Chenwulu Section, Guantai Rd., Houjie Town, Dongguan City, Guangdong 523942, China
Tested by (name and signature)	Dora Zhang 
Approved by (name and signature)	James Huang 
Manufacturer's name	EVOLVE ENERGY GROUP CO., LIMITED
Manufacturer address	RM 702, 7/F FU FAI COMM CTR 27 HILLIER ST SHEUNG WAN, HK
Factory's name	Dongguan SOFAR SOLAR Co.,Ltd.
Factory address	1F - 6F, Building E, No. 1 JinQi Road, Bihu Industrial Park, Wulian Village, Fenggang Town, Dongguan City

Document History			
Date	Internal reference	Modification / Change / Status	Revision
2019-07-05	Dora Zhang	Initial report was written	--
Supplementary information:			

Test items particulars	
Equipment mobility.....	: Permanent connection
Operating condition.....	: Continuous
Class of equipment	: Class I
Protection against ingress of water..	: IP65 according to EN 60529
Mass of equipment [kg].....	: 37
Test case verdicts	
Test case does not apply to the test object.....	: N/A
Test item does meet the requirement.....	: P(ass)
Test item does not meet the requirement.....	: F(ail)
Testing	
Date of receipt of test item	: 2018-07-12
Date(s) of performance of test	: 2018-07-12 to 2018-08-01
General remarks:	
<p>The test result presented in this report relate only to the object(s) tested. This report must not be reproduced in part or in full, without the written approval of the issuing testing laboratory.</p> <p>"(see Annex #)" refers to additional information appended to the report. "(see appended table)" refers to a table appended to the report.</p> <p>This is a copy test report, the test results refer to the original test report PV180712N013-2 issued by Bureau Veritas Shenzhen Co., Ltd. Dongguan Branch, dated on Aug. 03, 2018.</p> <p>Throughout this report a point is used as the decimal separator.</p>	
This Test Report consists of the following documents:	
<ol style="list-style-type: none"> 1. Test Results 2. Annex No. 1 – Pictures of the unit 3. Annex No. 2 – Test equipment list 	

Copy of marking plate:

<p>EVVO Solar Grid-tied Inverter</p> <p>Model No: EVVO 20000TLG23P</p> <p>Max.DC Input Voltage 1100V</p> <p>Operating MPPT Voltage Range 230-960V</p> <p>Max. Input Current 24A/24A</p> <p>Max. PV Isc 30A/30A</p> <p>Nominal Grid Voltage 3/N/PE,400Vac</p> <p>Max. Output Current 3x32A</p> <p>Nominal Grid Frequency 50/60Hz</p> <p>Nominal Output Power 20000W</p> <p>Max. Output Power 22000VA</p> <p>Power Factor >0.99(adjustable +/-0.8)</p> <p>Ingress Protection IP65</p> <p>Operating Temperature Range -25°C~+60°C</p> <p>Protection Class Class I</p> <p>Factory - Shenzhen China</p> <p>Manufacturer : EVOLVE ENERGY GROUP CO., LIMITED</p> <p>Address :RM 702, 7/F FU FAI COMM CTR 27 HILLIER ST SHEUNG WAN, HK</p> <p>Global Head Quarters 371 Sidco Industrial Estate Chennai 600098 India</p> <p>VDE0126-1-1,VDE-AR-N4105,G99,IEC61727, IEC62116,UTE C15-7-12-1,AS4777</p> 	<p>EVVO Solar Grid-tied Inverter</p> <p>Model No: EVVO 25000TLG23P</p> <p>Max.DC Input Voltage 1100V</p> <p>Operating MPPT Voltage Range 230-960V</p> <p>Max. Input Current 28A/28A</p> <p>Max. PV Isc 35A/35A</p> <p>Nominal Grid Voltage 3/N/PE,400Vac</p> <p>Max. Output Current 3x40A</p> <p>Nominal Grid Frequency 50/60Hz</p> <p>Nominal Output Power 25000W</p> <p>Max. Output Power 27500VA</p> <p>Power Factor >0.99(adjustable +/-0.8)</p> <p>Ingress Protection IP65</p> <p>Operating Temperature Range -25°C~+60°C</p> <p>Protection Class Class I</p> <p>Factory - Shenzhen China</p> <p>Manufacturer : EVOLVE ENERGY GROUP CO., LIMITED</p> <p>Address :RM 702, 7/F FU FAI COMM CTR 27 HILLIER ST SHEUNG WAN, HK</p> <p>Global Head Quarters 371 Sidco Industrial Estate Chennai 600098 India</p> <p>VDE0126-1-1,VDE-AR-N4105,G99,IEC61727, IEC62116,UTE C15-7-12-1,AS4777</p> 
<p>EVVO Solar Grid-tied Inverter</p> <p>Model No: EVVO 30000TLG23P</p> <p>Max.DC Input Voltage 1100V</p> <p>Operating MPPT Voltage Range 230-960V</p> <p>Max. Input Current 30A/30A</p> <p>Max. PV Isc 37.5A/37.5A</p> <p>Nominal Grid Voltage 3/N/PE,400Vac</p> <p>Max. Output Current 3x48A</p> <p>Nominal Grid Frequency 50/60Hz</p> <p>Nominal Output Power 30000W</p> <p>Max. Output Power 33000VA</p> <p>Power Factor >0.99(adjustable +/-0.8)</p> <p>Ingress Protection IP65</p> <p>Operating Temperature Range -25°C~+60°C</p> <p>Protection Class Class I</p> <p>Factory - Shenzhen China</p> <p>Manufacturer : EVOLVE ENERGY GROUP CO., LIMITED</p> <p>Address :RM 702, 7/F FU FAI COMM CTR 27 HILLIER ST SHEUNG WAN, HK</p> <p>Global Head Quarters 371 Sidco Industrial Estate Chennai 600098 India</p> <p>VDE0126-1-1,VDE-AR-N4105,G99,IEC61727, IEC62116,UTE C15-7-12-1,AS4777</p> 	<p>EVVO Solar Grid-tied Inverter</p> <p>Model No: EVVO 33000TLG23P</p> <p>Max.DC Input Voltage 1100V</p> <p>Operating MPPT Voltage Range 230-960V</p> <p>Max. Input Current 30A/30A</p> <p>Max. PV Isc 37.5A/37.5A</p> <p>Nominal Grid Voltage 3/N/PE,400Vac</p> <p>Max. Output Current 3x53A</p> <p>Nominal Grid Frequency 50/60Hz</p> <p>Nominal Output Power 33000W</p> <p>Max. Output Power 36300VA</p> <p>Power Factor >0.99(adjustable +/-0.8)</p> <p>Ingress Protection IP65</p> <p>Operating Temperature Range -25°C~+60°C</p> <p>Protection Class Class I</p> <p>Factory - Shenzhen China</p> <p>Manufacturer : EVOLVE ENERGY GROUP CO., LIMITED</p> <p>Address :RM 702, 7/F FU FAI COMM CTR 27 HILLIER ST SHEUNG WAN, HK</p> <p>Global Head Quarters 371 Sidco Industrial Estate Chennai 600098 India</p> <p>VDE0126-1-1,VDE-AR-N4105,G99,IEC61727, IEC62116,UTE C15-7-12-1,AS4777</p> 

General product information:

The Solar converter converts DC voltage into AC voltage.

The DC input of Solar converter can be supplied from PV array and Batteries.

The charging current to batteries only from PV array, battery management unit is integrated in External Energy storage.

The Solar converter is a three-phase type.

The unit is providing EMC filtering at the output toward mains. The unit does not provide galvanic separation from input to output (transformerless). The output is switched off redundant by the high power switching bridge and a two relays. This assures that the opening of the output circuit will also operate in case of one error.

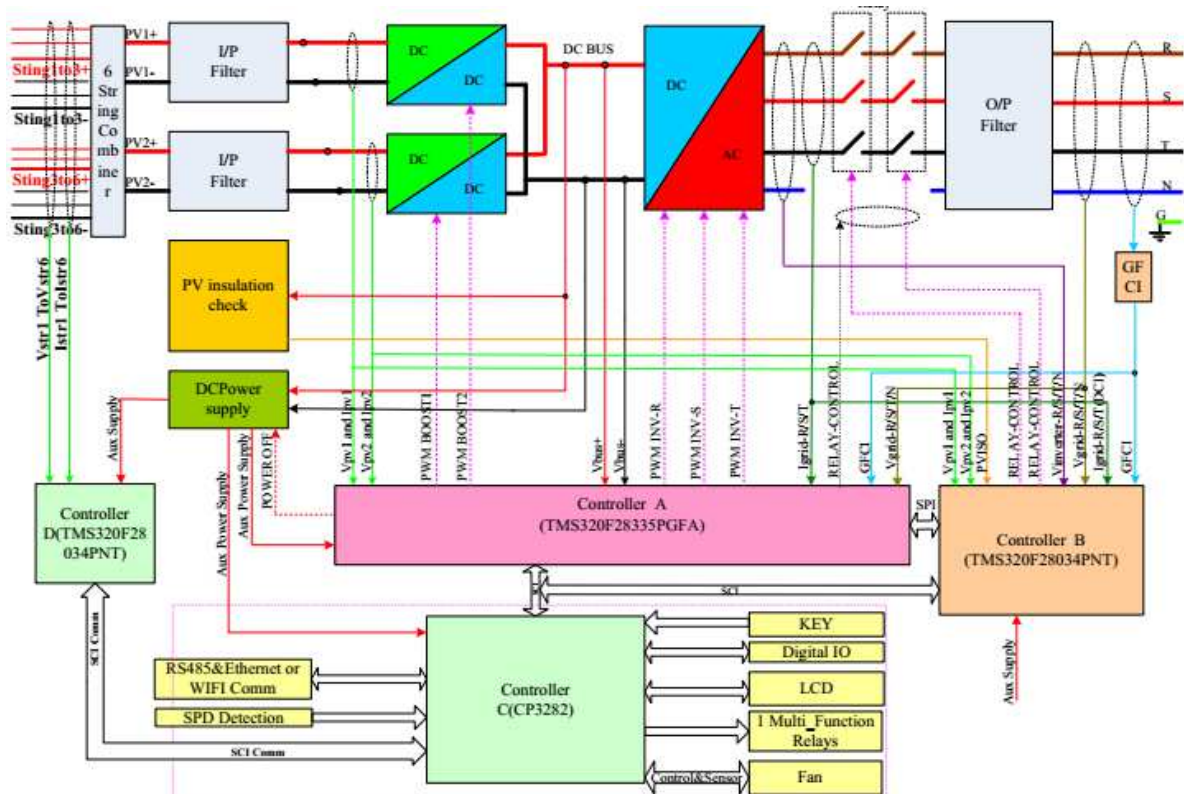

Figure 1-Block diagram

The internal control is redundant built. It consists of Main DSP(UC20) and slave DSP(UC73).

The Main DSP(UC20) can control the relays, measures voltage, and frequency, AC current with injected DC, insulation resistance and residual current, In addition it tests the array insulation resistance and the RCMU circuit before each start up.

The slave DSP(UC73) is using for detect residual current, also can open the relays independently and communicate with Main DSP(UC20).

The unit provides two relays in series on Line conductors. When single-fault applied to one relay, alarm an error code in display panel, another redundant relay provides basic insulation maintained between the PV array and the mains. All the relays are tested before start up. Both controllers(Main DSP(UC20), Slave DSP(UC73) can open the relays.

The product was tested on:

Hardware version: V1.00

Software version: V1.40

Model difference:

The models EVVO 20000TLG23P, EVVO 25000TLG23P, EVVO 30000TLG23P and EVVO 33000TLG23P are almost identical in hardware except the shown in the following table and the output power derated by software.

The difference in hardware			
Item	EVVO 20000TLG23P	EVVO 25000TLG23P	EVVO 30000TLG23P / EVVO 33000TLG23P
Number of PV terminal	2+2	3+3	
Number of BUS capacitance	8 capacitors: 550V/110 μ f 2 capacitors: 1100V/40 μ F		10 capacitors: 550V/110 μ f 4 capacitors: 1100V/40 μ F
INV inductance	785 μ H	735 μ H	
BUS board	Not the board	Have the board	
External fan	Not the board	2	3
Relay of output board	6pcs T9VV1K15-12S		3pcs AZSR250-2AE-12D

IEC 61683			
Clause	Requirement + Test	Result - Remark	Verdict
4	Efficiency measurement conditions	Considered.	P
	Efficiency shall be measured under the matrix of conditions as described in the following clauses and table 1. Specific conditions may be excluded by mutual agreement when those conditions are outside the manufacturer's allowable operating range. The resulting data shall be presented in tabular form and may also be presented graphically.	See below.	P
4.1	DC power source for testing		P
	For power conditioners operating with fixed input voltage, the d.c. power source is a storage battery or constant voltage power source to maintain the input voltage.		N/A
	For power conditioners that employ maximum power point tracking (MPPT) and shunt-type power conditioners, either a photovoltaic array or a photovoltaic array simulator is utilized.	Photovoltaic array simulator used.	P
4.2	Temperature		P
	All measurements are to be made at an ambient temperature of 25 °C ± 2 °C.	25°C	P
	Other ambient temperatures may be allowed by mutual agreement. However, the temperature used must be clearly stated in all documentation.		N/A
4.3	Output voltage and frequency		P
	The output voltage and frequency are maintained at the manufacturer's stated nominal values.	230V, 3/N/PE, 50Hz	P
4.4	Input voltage		P
	Measurements performed in each of the following tests are repeated at three power conditioner input voltages: a) manufacturer's minimum rated input voltage; b) the inverter's nominal voltage or the average of its rated input range; c) 90 % of the inverter's maximum input voltage.	Input voltages: a) ; EVVO 20000TLG23P: 480Vdc, EVVO 25000TLG23P : 460Vdc, EVVO 30000TLG23P : 520Vdc, EVVO 33000TLG23P : 580Vdc b); 620V c) . 990V	P
	In the case where a power conditioner is to be connected with a battery at its input terminals, only the nominal or rated input voltage may be applied.		N/A
4.5	Ripple and distortion		P

IEC 61683			
Clause	Requirement + Test	Result - Remark	Verdict
	Record input voltage and current ripple for each measurement. Also record output voltage and current distortion (if a.c.) or ripple (if d.c.). Ensure that these measurements remain within the manufacturer's specified values.	The ripple of the input voltage had no influence on the measurements. (see appended table)	P
4.6	Resistive loads/utility grid		P
	At unity power factor, or at the intrinsic power factor of grid-connected inverters without power factor adjustment, measure the efficiency for power levels of 10 %, 25 %, 50 %, 75 %, 100 % and 120 % of the inverter's rating.	The efficiency measurement was performed at 10 %, 25 %, 50 %, 75 % and 100 %, because the unit does not provide 120% of the inverter's rating overload function.	P
	Stand-alone inverters are also measured at a power level of 5 % of rated. The power conditioner test is conducted with a specified resistive and reactive grid impedance.	Grid-connected inverters.	N/A
4.7	Reactive loads		N/A
	For stand-alone inverters, measure the efficiency with a load which provides a power factor equal to the manufacturer's specified minimum level (or 0,25, whichever is greater) and at power levels of 25 %, 50 % and 100 % of rated VA.	Grid-connected inverters.	N/A
	Repeat for power factors of 0,5 and 0,75 (do not go below the manufacturer's specified minimum PF) and power levels of 25 %, 50 %, and 100 % of rated VA.		N/A
4.8	Resistive plus non-linear loads		N/A
	For stand-alone inverters, measure the efficiency with a fixed non-linear load (total harmonic distortion (THD) = $(80 \pm 5) \%$) equal to $(25 \pm 5) \%$ of the inverter's rated VA plus sufficient resistive load in parallel to achieve a total load of 25 %, 50 % and 100 % of rated VA.	Grid-connected inverters.	N/A
	Repeat the measurements with a fixed non-linear load equivalent to $(50 \pm 5) \%$ of the inverter's rated VA plus sufficient resistive load in parallel to achieve a total load of 50% and 100% of rated VA.		N/A
	The type of non-linear load must be clearly stated in all documentation.		N/A
4.9	Complex loads		N/A
	When a non-linear plus a sufficient reactive load condition is specified for stand-alone inverters, measure the efficiency with a fixed non-linear load (THD = $(80 \pm 5) \%$) equal to $(50 \pm 5) \%$ of the inverter's rated VA plus a sufficient reactive load (PF = 0,5) in parallel to achieve a total load of 50 % and 100 % of rated VA.	Grid-connected inverters.	N/A
	The type of complex load is clearly stated in all documentation.		N/A

IEC 61683			
Clause	Requirement + Test	Result - Remark	Verdict

5.	Efficiency calculations	See below.	P
5.1	Rated output efficiency		P
	Rated output efficiency shall be calculated from measured data as follows: $\eta_R = (P_o / P_i) \times 100$	Considered.	P
5.2	Partial output efficiency		N/A
	Partial output efficiency shall be calculated from measured data as follows: $\eta_{par} = (P_{op} / P_{ip}) \times 100$	No derating during testing.	N/A
5.3	Energy efficiency		P
	Energy efficiency shall be calculated from measured data as follows: $\eta_E = (W_o / W_i) \times 100$	Considered.	P
5.4	Efficiency tolerances		P
	When an efficiency value has been guaranteed, the tolerance of this value shall be within: $-0,2(1-\eta)\eta$ (%)	Considered.	P

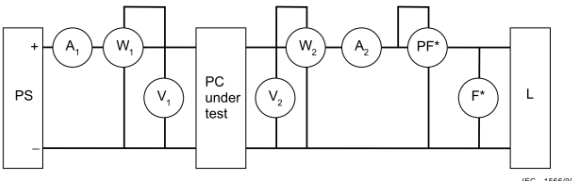
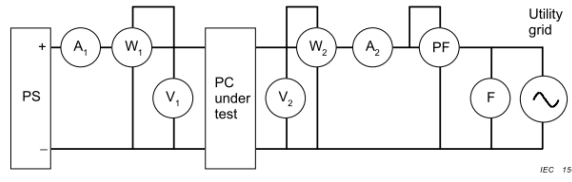
6.	Efficiency test circuits	See below.	P
6.1	Test circuits	Considered.	P
	Figure 1a is applied to standard-alone power conditioners	Figure 1b used.	N/A
	 <p>Figure 1a – Stand-alone type</p>		N/A
	Figure 1b is applied to utility-interactive power conditioners	Considered.	P
	 <p>Figure 1b – Utility-interactive type</p> <p>PC power conditioner PS variable voltage-current d.c. power supply A₁ DC ammeter A₂ AC or d.c. ammeter W₁ DC wattmeter W₂ AC or d.c. wattmeter L load F frequency meter V₁ DC voltmeter V₂ AC or d.c. voltmeter PF power factor meter</p>		P
6.2	Measurement procedure	Considered.	P

IEC 61683			
Clause	Requirement + Test	Result - Remark	Verdict
	a) Efficiency is calculated with equation (1) or (2) using measured P_i , P_o or P_{ip} , P_{op} . DC input power P_i , P_{ip} can be measured by wattmeter W_1 , or determined by multiplying the d.c. voltmeter V_1 and d.c. ammeter A_1 readings. Output power P_o , P_{op} is measured with wattmeter W_2 .	Considered.	P
	b) DC input voltage, which is measured by d.c. voltmeter V_1 , shall be varied in the defined range where the output current, which is measured with a.c. ammeter A_2 , is varied from low output to the rated output.	Considered.	P
	c) An average indicating instrument shall be used for the d.c. voltmeter and d.c. ammeter. A true r.m.s. type of indicating instrument shall be used for the a.c. voltmeter and a.c. ammeter. The d.c. wattmeter W_1 shall be a d.c. measuring type. The wattmeter W_2 shall be an a.c. or d.c. measuring type according to the output.	Considered.	P
	d) Power factor (PF in per cent) can be measured by a power factor meter PF, or calculated from the readings of V_2 , A_2 , W_2 and as follows: $PF = (W_2 / (V_2 \times A_2)) \times 100$	Considered.	P
	e) Each meter may be an analogue type or a digital type. The measurement accuracy shall be better than $\pm 0,5\%$ of the full-scale value for each power measured. Digital power instruments for W_1 and W_2 are also recommended.	Digital measurement devices were used for testing. The accuracy of the measurement devices fulfills the requirements.	P
	f) An MPPT dynamically adjusts the input voltage so as to maximize the output power. In principle, the monitoring equipment shall sample all of the electrical parameters, such as input voltage and current, output power and current, within the update period of the MPPT. If the MPPT and input source (PV array or PV array simulator) interact in such a way that the input voltage varies by less than 5 %, then averaging of readings is acceptable. The averaging period shall be 30 s or longer.	The dynamic MPPT was deactivated, the 60s average was used anyway.	P

7.	Loss measurement	See below.	P
7.1	No-load loss		P
	Stand-alone inverters: reading of d.c. input voltage, output voltage and frequency is given with meters V_1 , V_2 and F respectively in figure 1a, and shall be adjusted to the rated values.	Grid-connected inverters.	N/A
	Utility-interactive inverters: reading of d.c. input voltmeter V_1 , a.c. output voltmeter V_2 and frequency meter F in figure 1b shall be adjusted to meet the specified voltages and frequency.	See appended table.	P
7.2	Standby loss		P

IEC 61683			
Clause	Requirement + Test	Result - Remark	Verdict
	Stand-alone inverters: Consumption of utility power when the power conditioner is not operating but is under standby condition.	No such inverters.	N/A
	Utility-interactive inverters: consumption from the d.c. source when the power conditioner is not operating but is under standby condition.	See appended table.	P
Annex A	Power conditioner description (informative)	See below.	P
	A power conditioner is defined in IEC 61277	Figure A.2	P
Annex B	Power efficiency and conversion factor (informative)	See below.	P
	There are two types of efficiencies shown in IEC 60146-2; one is a power efficiency, the other is a conversion factor. Power efficiency is defined as the ratio of active output power and active input power. Conversion factor is the ratio between output and input fundamental power levels.	Power efficiency used.	P
Annex C	Weighted-average energy efficiency (informative)	See below.	P
	The energy of a power conditioner depends on both the irradiance profile and the load profile. The energy efficiency of a power conditioner shall be calculated by the ratio of the output to the input energy actually measured over a certain period	Considered.	P
C.1	η_{WT} of power conditioner for utility-interactive PV systems	EVVO 20000TLG23P: 97.67% EVVO 25000TLG23P: 97.76% EVVO 30000TLG23P: 97.43% EVVO 33000TLG23P: 97.73%	P
	Utility-interactive PV systems, which have no storage and for which reverse-power flow is accepted, are described. In this case, d.c. power generated by the PV array is supplied direct into the power conditioner (PC). Almost all of the input power to the PC is converted to a.c. power. A part of it is dissipated as the PC loss.	Considered.	P
C.2	η_{WT} of power conditioner for stand-alone PV systems	Grid-connected inverters.	N/A
	In stand-alone PV systems with a storage subsystem, power generated from the PV array is stored and stabilized by the batteries. DC power is converted into regulated d.c. power or constant-voltage and constant-frequency a.c. power by a power conditioner (PC) and supplied to the load. In this case, some fraction of the generated power is dissipated as a loss in the batteries and power conditioner.		N/A



IEC 61683			
Clause	Requirement + Test	Result - Remark	Verdict
Annex D	Derivation of efficiency tolerance in table 2 (informative)	Considered.	P

IEC 61683			
Clause	Requirement + Test	Result - Remark	Verdict

TABLE	Efficiency recording and efficient calculation sheet								
power conditioner type	Grid-connected								
Model:	EVVO 20000TLG23P								
Parameters of power conditioner	Minimum rated input voltage: 480V Nominal voltage: 620V Maximum input voltage: 1100V Rated output voltage: 400V Rated output frequency: 50Hz Rated output power: 22kVA								
PV input voltage	a) Manufacturer's minimum rated input voltage								
Temperature (°C)	25								
Operating period for energy measurement (min)	2								
Percentage of rated output VA	/	10%	25%	50%	75%	100%	120%*	/	/
Input voltage (V)	/	479.39	479.15	478.32	478.84	478.30	/	/	/
Input voltage ripple (V)	/	14.54	10.71	9.06	6.60	4.92	/	/	/
Input current (A)	/	4.277	10.711	21.444	32.552	43.309	/	/	/
Input current ripple (A)	/	0.131	0.241	0.393	0.389	0.371	/	/	/
Input power (Pi) (kW)	/	2.049	5.131	10.256	15.581	20.710	/	/	/
Output power (Po) (kW)	/	1.951	4.977	9.999	15.183	20.169	/	/	/
Output efficiency (%)	/	95.21	96.99	97.49	97.45	97.39	/	/	/
Input energy (Wi) (kWh)	/	0.068	0.171	0.342	0.519	0.690	/	/	/
Output energy (Wo) (kWh)	/	0.065	0.166	0.333	0.506	0.673	/	/	/
Energy efficiency	/	95.21	97.06	97.56	97.51	97.45	/	/	/
PV input voltage	b) The inverter's nominal voltage								
Temperature (°C)	25								
Operating period for energy measurement (min)	2								
Percentage of rated output VA	/	10%	25%	50%	75%	100%	120%*	/	/
Input voltage (V)	/	618.79	619.07	619.06	618.63	618.89	/	/	/
Input voltage ripple (V)	/	17.63	13.61	13.20	10.21	7.52	/	/	/
Input current (A)	/	3.310	8.296	16.587	24.886	33.242	/	/	/

IEC 61683									
Clause	Requirement + Test						Result - Remark		Verdict
Input current ripple (A)	/	0.09	0.18	0.35	0.40	0.40	/	/	/
Input power (Pi) (kW)	/	2.047	5.135	10.267	15.394	20.570	/	/	/
Output power (Po) (kW)	/	1.955	4.992	10.028	15.041	20.169	/	/	/
Output efficiency (%)	/	95.54	97.23	97.67	97.71	98.05	/	/	/
Input energy (Wi) (kWh)	/	0.068	0.171	0.342	0.513	0.685	/	/	/
Output energy (Wo) (kWh)	/	0.065	0.166	0.334	0.502	0.673	/	/	/
Energy efficiency	/	95.54	97.30	97.75	97.78	98.12	/	/	/
PV input voltage	c) 90% of the inverter's maximum input voltage**								
Temperature (°C)	/								
Operating period for energy measurement (min)	/								
Percentage of rated output VA	/	10%	25%	50%	75%	100%	120%*	/	/
Input voltage (V)	/	/	/	/	/	/	/	/	/
Input voltage ripple (V)	/	/	/	/	/	/	/	/	/
Input current (A)	/	/	/	/	/	/	/	/	/
Input current ripple (A)	/	/	/	/	/	/	/	/	/
Input power (Pi) (kW)	/	/	/	/	/	/	/	/	/
Output power (Po) (kW)	/	/	/	/	/	/	/	/	/
Output efficiency (%)	/	/	/	/	/	/	/	/	/
Input energy (Wi) (kWh)	/	/	/	/	/	/	/	/	/
Output energy (Wo) (kWh)	/	/	/	/	/	/	/	/	/
Energy efficiency	/	/	/	/	/	/	/	/	/
Remark: *If limited by design, inverter is not capable to operate with the 120% of rated output load, test under this condition is waived; ** The EUT can't start up at 990Vdc.									

TABLE	Efficiency recording and efficient calculation sheet
power conditioner type	Grid-connected
Model:	EVVO 25000TLG23P

IEC 61683										
Clause	Requirement + Test							Result - Remark		Verdict
Parameters of power conditioner	Minimum rated input voltage: 460V Nominal voltage: 620V Maximum input voltage: 1100V Rated output voltage: 400V Rated output frequency: 50Hz Rated output power: 27.5kVA									
PV input voltage	a) Manufacturer's minimum rated input voltage									
Temperature (°C)	25									
Operating period for energy measurement (min)	2									
Percentage of rated output VA	/	10%	25%	50%	75%	100%	120%*	/	/	
Input voltage (V)	/	459.25	459.48	458.30	466.23	466.23	/	/	/	
Input voltage ripple (V)	/	12.84	8.58	9.17	10.23	10.23	/	/	/	
Input current (A)	/	5.551	13.878	27.793	54.594	54.594	/	/	/	
Input current ripple (A)	/	0.155	0.266	0.563	2.250	2.250	/	/	/	
Input power (Pi) (kW)	/	2.548	6.376	12.736	25.450	25.450	/	/	/	
Output power (Po) (kW)	/	2.439	6.193	12.415	24.769	24.769	/	/	/	
Output efficiency (%)	/	95.73	97.14	97.48	97.32	97.32	/	/	/	
Input energy (Wi) (kWh)	/	0.085	0.212	0.423	0.848	0.848	/	/	/	
Output energy (Wo) (kWh)	/	0.081	0.206	0.412	0.826	0.826	/	/	/	
Energy efficiency	/	95.73	97.21	97.55	97.39	97.39	/	/	/	
PV input voltage	b) The inverter's nominal voltage									
Temperature (°C)	25									
Operating period for energy measurement (min)	2									
Percentage of rated output VA	/	10%	25%	50%	75%	100%	120%*	/	/	
Input voltage (V)	/	618.66	619.09	618.60	619.10	618.62	/	/	/	
Input voltage ripple (V)	/	16.77	13.59	11.37	8.34	6.89	/	/	/	
Input current (A)	/	4.121	10.310	20.626	30.973	41.197	/	/	/	
Input current ripple (A)	/	0.107	0.222	0.369	0.393	0.456	/	/	/	
Input power (Pi) (W)	/	2.548	6.381	12.758	19.172	25.481	/	/	/	
Output power (Po) (W)	/	2.448	6.217	12.466	18.786	24.950	/	/	/	
Output efficiency	/	96.05	97.43	97.71	97.99	97.92	/	/	/	

IEC 61683									
Clause	Requirement + Test						Result - Remark		Verdict
Input energy (Wi) (kWh)	/	0.085	0.212	0.423	0.636	0.849	/	/	/
Output energy (Wo) (kWh)	/	0.081	0.206	0.414	0.624	0.832	/	/	/
Energy efficiency	/	96.05	97.50	97.78	98.05	97.98	/	/	/
PV input voltage	c) 90% of the inverter's maximum input voltage**								
Temperature (°C)	/								
Operating period for energy measurement (min)	/								
Percentage of rated output VA	/	10%	25%	50%	75%	100%	120%*	/	/
Input voltage (V)	/	/	/	/	/	/	/	/	/
Input voltage ripple (V)	/	/	/	/	/	/	/	/	/
Input current (A)	/	/	/	/	/	/	/	/	/
Input current ripple (A)	/	/	/	/	/	/	/	/	/
Input power (Pi) (W)	/	/	/	/	/	/	/	/	/
Output power (Po) (W)	/	/	/	/	/	/	/	/	/
Output efficiency	/	/	/	/	/	/	/	/	/
Input energy (Wi) (kWh)	/	/	/	/	/	/	/	/	/
Output energy (Wo) (kWh)	/	/	/	/	/	/	/	/	/
Energy efficiency	/	/	/	/	/	/	/	/	/
Remark: *If limited by design, inverter is not capable to operate with the 120% of rated output load, test under this condition is waived; ** The EUT can't start up at 990Vdc.									

TABLE	Efficiency recording and efficient calculation sheet
power conditioner type	Grid-connected
Model:	EVVO 30000TLG23P
Parameters of power conditioner	Minimum rated input voltage: 520V Nominal voltage: 620V Maximum input voltage: 1100V Rated output voltage: 400V Rated output frequency: 50Hz Rated output power: 33.0kVA
PV input voltage	a) Manufacturer's minimum rated input voltage
Temperature (°C)	25

IEC 61683									
Clause	Requirement + Test							Result - Remark	Verdict
Operating period for energy measurement (min)	2								
Percentage of rated output VA	/	10%	25%	50%	75%	100%	120%*	/	/
Input voltage (V)	/	520.58	519.76	518.94	518.42	518.69	/	/	/
Input voltage ripple (V)	/	14.37	11.40	6.56	6.27	3.50	/	/	/
Input current (A)	/	5.941	14.881	30.130	44.603	59.630	/	/	/
Input current ripple (A)	/	0.169	0.327	0.193	0.439	0.468	/	/	/
Input power (Pi) (kW)	/	3.092	7.733	15.626	23.115	30.923	/	/	/
Output power (Po) (kW)	/	2.984	7.539	15.235	22.518	30.083	/	/	/
Output efficiency (%)	/	96.52	97.50	97.50	97.42	97.28	/	/	/
Input energy (Wi) (kWh)	/	0.103	0.257	0.519	0.767	1.026	/	/	/
Output energy (Wo) (kWh)	/	0.099	0.250	0.506	0.748	0.999	/	/	/
Energy efficiency	/	96.53	97.58	97.57	97.48	97.35	/	/	/
PV input voltage	b) The inverter's nominal voltage								
Temperature (°C)	25								
Operating period for energy measurement (min)	2								
Percentage of rated output VA	/	10%	25%	50%	75%	100%	120%*	/	/
Input voltage (V)	/	621.74	620.18	619.06	618.88	618.36	/	/	/
Input voltage ripple (V)	/	15.09	15.05	9.79	7.52	7.35	/	/	/
Input current (A)	/	4.972	12.477	24.974	37.168	49.920	/	/	/
Input current ripple (A)	/	0.122	0.299	0.388	0.374	0.604	/	/	/
Input power (Pi) (kW)	/	3.090	7.737	15.459	22.996	30.863	/	/	/
Output power (Po) (kW)	/	2.985	7.548	15.105	22.521	30.184	/	/	/
Output efficiency (%)	/	96.61	97.56	97.71	97.93	97.80	/	/	/
Input energy (Wi) (kWh)	/	0.103	0.257	0.513	0.763	1.024	/	/	/
Output energy (Wo) (kWh)	/	0.099	0.251	0.502	0.748	1.002	/	/	/
Energy efficiency	/	96.61	97.63	97.79	98.00	97.87	/	/	/
PV input voltage	c) 90% of the inverter's maximum input voltage**								
Temperature (°C)	/								
Operating period for energy measurement (min)	/								

IEC 61683									
Clause	Requirement + Test							Result - Remark	Verdict
Percentage of rated output VA	/	10%	25%	50%	75%	100%	120%*	/	/
Input voltage (V)	/	/	/	/	/	/	/	/	/
Input voltage ripple (V)	/	/	/	/	/	/	/	/	/
Input current (A)	/	/	/	/	/	/	/	/	/
Input current ripple (A)	/	/	/	/	/	/	/	/	/
Input power (Pi) (kW)	/	/	/	/	/	/	/	/	/
Output power (Po) (kW)	/	/	/	/	/	/	/	/	/
Output efficiency (%)	/	/	/	/	/	/	/	/	/
Input energy (Wi) (kWh)	/	/	/	/	/	/	/	/	/
Output energy (Wo) (kWh)	/	/	/	/	/	/	/	/	/
Energy efficiency	/	/	/	/	/	/	/	/	/
Remark: *If limited by design, inverter is not capable to operate with the 120% of rated output load, test under this condition is waived; ** The EUT can't start up at 990Vdc.									

TABLE	Efficiency recording and efficient calculation sheet								
power conditioner type	Grid-connected								
Model:	EVVO 33000TLG23P								
Parameters of power conditioner	Minimum rated input voltage: 580V Nominal voltage: 620V Maximum input voltage: 1100V Rated output voltage: 400V Rated output frequency: 50Hz Rated output power: 36.3kVA								
PV input voltage	a) Manufacturer's minimum rated input voltage								
Temperature (°C)	25								
Operating period for energy measurement (min)	2								
Percentage of rated output VA	/	10%	25%	50%	75%	100%	120%*	/	/
Input voltage (V)	/	579.65	579.83	579.72	578.46	577.60	/	/	/
Input voltage ripple (V)	/	16.02	12.61	8.87	5.55	0.80	/	/	/
Input current (A)	/	5.852	14.634	28.889	43.824	58.336	/	/	/
Input current ripple (A)	/	0.162	0.315	0.444	0.377	0.125	/	/	/
Input power (Pi) (kW)	/	3.391	8.484	16.746	25.343	33.694	/	/	/

IEC 61683									
Clause	Requirement + Test						Result - Remark		Verdict
Output power (Po) (kW)	/	3.287	8.290	16.370	24.702	32.762	/	/	/
Output efficiency (%)	/	96.91	97.70	97.75	97.47	97.23	/	/	/
Input energy (Wi) (kWh)	/	0.113	0.282	0.556	0.841	1.118	/	/	/
Output energy (Wo) (kWh)	/	0.109	0.275	0.544	0.820	1.088	/	/	/
Energy efficiency	/	96.92	97.78	97.83	97.54	97.30	/	/	/
PV input voltage									
b) The inverter's nominal voltage									
Temperature (°C)	25								
Operating period for energy measurement (min)	2								
Percentage of rated output VA	/	10%	25%	50%	75%	100%	120%*	/	/
Input voltage (V)	/	620.12	620.08	619.08	618.67	617.93	/	/	/
Input voltage ripple (V)	/	15.18	13.15	10.10	7.36	2.79	/	/	/
Input current (A)	/	5.470	13.685	27.382	40.808	54.266	/	/	/
Input current ripple (A)	/	0.135	0.295	0.444	0.434	0.268	/	/	/
Input power (Pi) (kW)	/	3.391	8.485	16.949	25.241	33.530	/	/	/
Output power (Po) (kW)	/	3.281	8.282	16.558	24.708	32.770	/	/	/
Output efficiency (%)	/	96.74	97.62	97.69	97.89	97.73	/	/	/
Input energy (Wi) (kWh)	/	0.113	0.283	0.565	0.838	1.113	/	/	/
Output energy (Wo) (kWh)	/	0.109	0.276	0.552	0.820	1.088	/	/	/
Energy efficiency	/	96.76	97.69	97.77	97.95	97.80	/	/	/
PV input voltage									
c) 90% of the inverter's maximum input voltage**									
Temperature (°C)	/								
Operating period for energy measurement (min)	/								
Percentage of rated output VA	/	10%	25%	50%	75%	100%	120%*	/	/
Input voltage (V)	/	/	/	/	/	/	/	/	/
Input voltage ripple (V)	/	/	/	/	/	/	/	/	/
Input current (A)	/	/	/	/	/	/	/	/	/
Input current ripple (A)	/	/	/	/	/	/	/	/	/
Input power (Pi) (kW)	/	/	/	/	/	/	/	/	/
Output power (Po) (kW)	/	/	/	/	/	/	/	/	/

IEC 61683									
Clause	Requirement + Test					Result - Remark			Verdict
Output efficiency (%)	/	/	/	/	/	/	/	/	/
Input energy (Wi) (kWh)	/	/	/	/	/	/	/	/	/
Output energy (Wo) (kWh)	/	/	/	/	/	/	/	/	/
Energy efficiency	/	/	/	/	/	/	/	/	/
Remark: *If limited by design, inverter is not capable to operate with the 120% of rated output load, test under this condition is waived; ** The EUT can't start up at 990Vdc.									

IEC 61683			
Clause	Requirement + Test	Result - Remark	Verdict

TABLE	No load loss: EVVO 20000TLG23P		
power conditioner type	Utility-interactive		
Measure input voltage (V)	618.36		
Measured input power(W)	21.48		
Remark: No load loss is measured when the power conditioner works at rated input voltage and it's load is disconnected.			

TABLE	No load loss: EVVO 25000TLG23P		
power conditioner type	Utility-interactive		
Measure input voltage (V)	619.82		
Measured input power(W)	21.94		
Remark: No load loss is measured when the power conditioner works at rated input voltage and it's load is disconnected.			

TABLE	No load loss: EVVO 30000TLG23P		
power conditioner type	Utility-interactive		
Measure input voltage (V)	620.41		
Measured input power(W)	22.83		
Remark: No load loss is measured when the power conditioner works at rated input voltage and it's load is disconnected.			

TABLE	No load loss: EVVO 33000TLG23P		
power conditioner type	Utility-interactive		
Measure input voltage (V)	620.41		
Measured input power(W)	22.88		
Remark: No load loss is measured when the power conditioner works at rated input voltage and it's load is disconnected.			

IEC 61683			
Clause	Requirement + Test	Result - Remark	Verdict

TABLE	Standby loss: EVVO 20000TLG23P		
power conditioner type	Utility-interactive		
Measure input voltage (V)	0.14		
Measured input power(W)	1.97		
Remark: Standby loss is measured when the power conditioner works at rated input voltage and in standby mode.			

TABLE	Standby loss: EVVO 25000TLG23P		
power conditioner type	Utility-interactive		
Measure input voltage (V)	0.14		
Measured input power(W)	1.97		
Remark: Standby loss is measured when the power conditioner works at rated input voltage and in standby mode.			

TABLE	Standby loss: EVVO 30000TLG23P		
power conditioner type	Utility-interactive		
Measure input voltage (V)	0.15		
Measured input power(W)	1.98		
Remark: Standby loss is measured when the power conditioner works at rated input voltage and in standby mode.			

TABLE	Standby loss: EVVO 33000TLG23P		
power conditioner type	Utility-interactive		
Measure input voltage (V)	0.14		
Measured input power(W)	1.98		
Remark: Standby loss is measured when the power conditioner works at rated input voltage and in standby mode.			

Annex 1

Pictures of the unit
The full pictures refer to PHOTO DOCUMENT
Project No.: 190308N051
Date: 20190705

Enclosure front view:



Enclosure rear view: EVVO 20000TLG23P

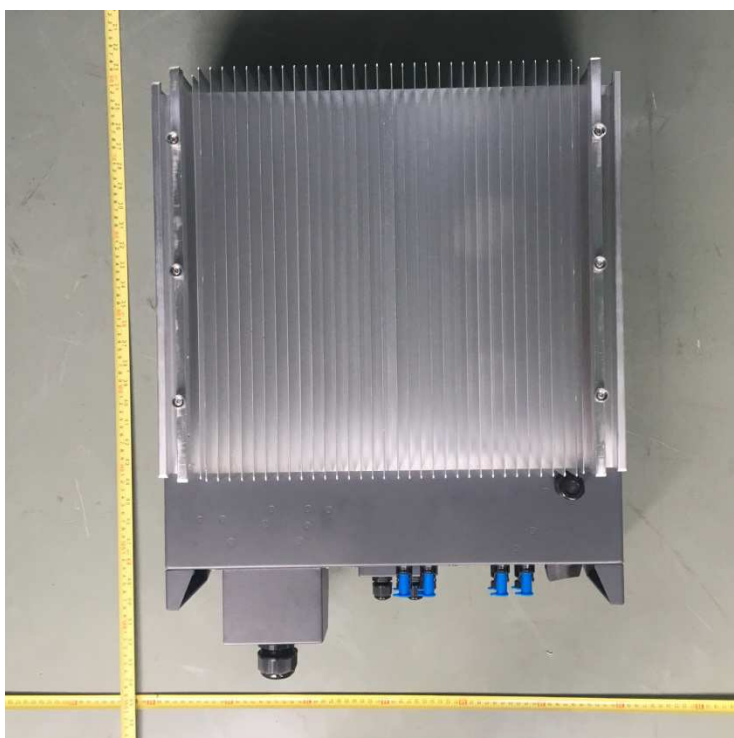

Enclosure rear view: EVVO 25000TLG23P, EVVO 30000TLG23P, EVVO 33000TLG23P

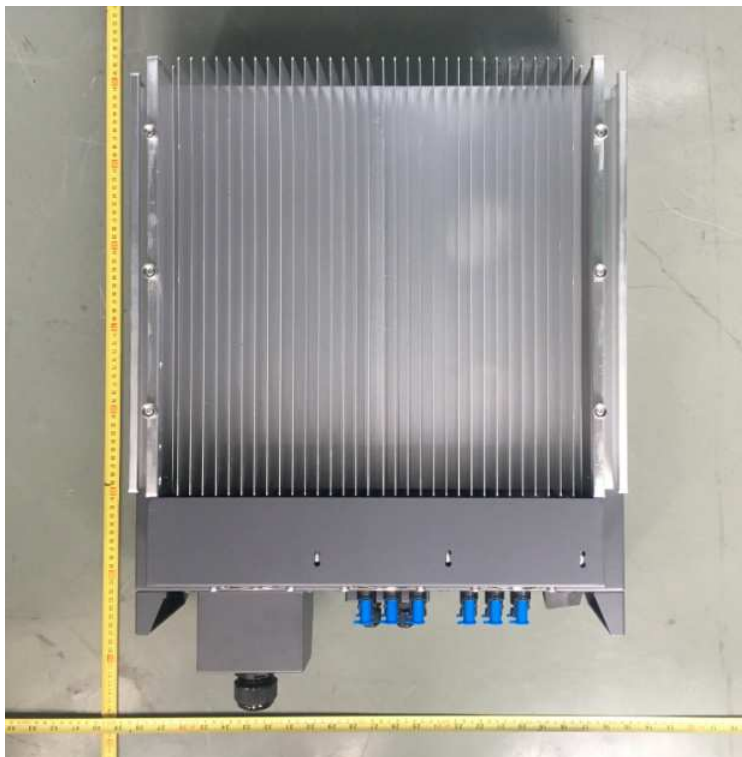

Enclosure terminal view: EVVO 20000TLG23P



Enclosure terminal view: EVVO 25000TLG23P



Enclosure terminal view: EVVO 30000TLG23P, EVVO 33000TLG23P



Annex 2

Test equipment list

Test location: Bureau Veritas Shenzhen Co., Ltd. Dongguan Branch
Dates of performance test: 2018-07-12 to 2018-08-01

Equipment	Internal No.	Manufacturer	Type	Serial No.	Last Calibration
Power Analyzer	A4080002DG	YOKOGAWA	WT3000	91M210852	Jan. 12, 2018
AC Source	A7040019DG	Chroma	61512	61512000439	Monitored by Power Analyzer
	A7040020DG	Chroma	61512	61512000438	
DC Simulation Power Supply	A7040015DG	Chroma	62150H-1000S	62150EF00488	
	A7040016DG	Chroma	62150H-1000S	62150EF00490	
	A7040017DG	Chroma	620028	620028EF00120	
RLC Load	A7150027DG	Qunling	ACLT-3803H	93VOO2869	